



STEEL BUTT-WELDING PIPE FITTINGS

JIS B 2311, 2312, 2313

KS B1522, 1541, 1543

ISO 9001



FURUBAYASHI KOGYO KABUSHIKIGAISSYA VIETNAM

FKK VIETNAM

世界に誇る  溶接式管継手

弊社は、1939年創業以来の
伝統と歴史を持つ日本の親企業を
母体とし、技術陣が長年研究を
重ね製作された定評ある
FKK品質を基本に、2014年2月に
ベトナムに創立致しました。

弊社は顧客要求事項を重視し
顧客満足を実現する為、
全世界に通用する
高い品質レベルの製品を
提供しております。

 **Pride of international grade
for Steel Butt-Welding Pipe
Fittings products.**

Our parent company has its main
factory in Japan with history and
tradition since 1939. Based on the
reputation of FKK for the good
quality products produced by the
qualified experience technical staff,
we have established FKK Vietnam
since February 2014.

Our company focus on the
requirements of customers and
we readily provide products with
high quality, popular all over the
world to meet the demands of
the esteemed customers.

Phụ kiện nối ống hàn 
Thương hiệu hàng đầu thế giới.

Công ty mẹ của chúng tôi có nhà
máy chính tại Nhật Bản với lịch sử
và truyền thống có từ năm 1939,
công ty chúng tôi lấy chất lượng
FKK danh tiếng được sản xuất bởi
đội ngũ kỹ thuật dày dặn nhiều
năm nghiên cứu phát triển làm nền
tảng để sáng lập nhà máy sản xuất
tại Việt Nam vào tháng 2 năm 2014.

Công ty chúng tôi rất chú trọng
các yêu cầu của khách hàng và
luôn cung cấp những sản phẩm có
chất lượng cao, phổ biến trên toàn
thế giới để thỏa mãn nhu cầu của
Quý khách hàng.



STANDARDS OF WELDING FITTINGS

FKK's Steel Butt-Welding Fittings are in accordance with the following applicable International Quality Standard:

APPROVAL ORGANIZATION: KOREAN STANDARDS ASSOCIATION (KSA)			CERTIFICATE NUMBER
JAPAN	JIS B 2311	Steel Butt-Welding Pipe Fittings for Ordinary Use.	KSVN15001
	JIS B 2312	Steel Butt-Welding Pipe Fittings.	KSVN15002
	JIS B 2313	Steel Plate Butt-Welding Pipe Fittings.	KSVN15003
KOREA	KS B 1522	Steel Butt-Welding Pipe Fittings for Ordinary Use and Fuel Gas.	15-0159
	KS B 1541	Steel Butt-Welding Pipe Fittings.	15-0160
	KS B 1543	Steel Plate Butt-Welding Pipe Fittings.	15-0161
ISO 9001			QMS-4133



180° Elbows



90° Elbows



45° Elbows



Caps



Straight Tees



Reducing Tees



Concentric Reducers



Eccentric Reducers



FOR MATERIAL OF PIPE:

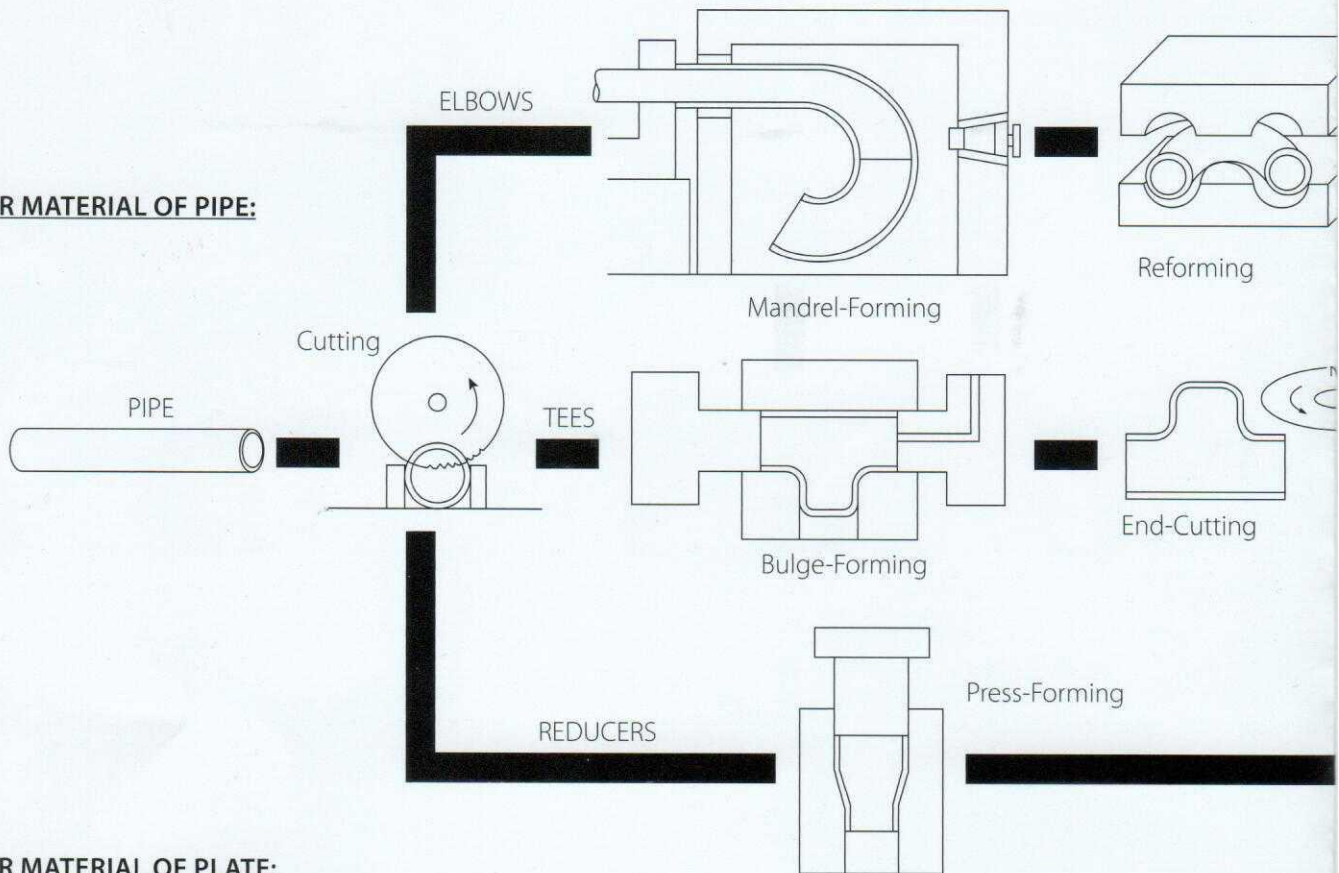

FOR MATERIAL OF PLATE:

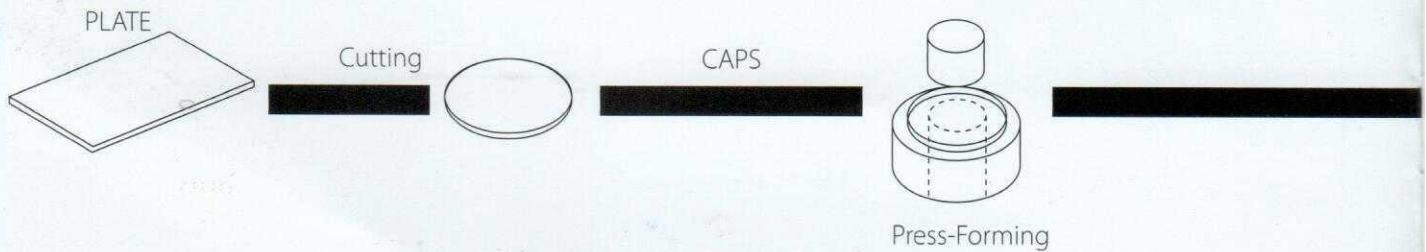

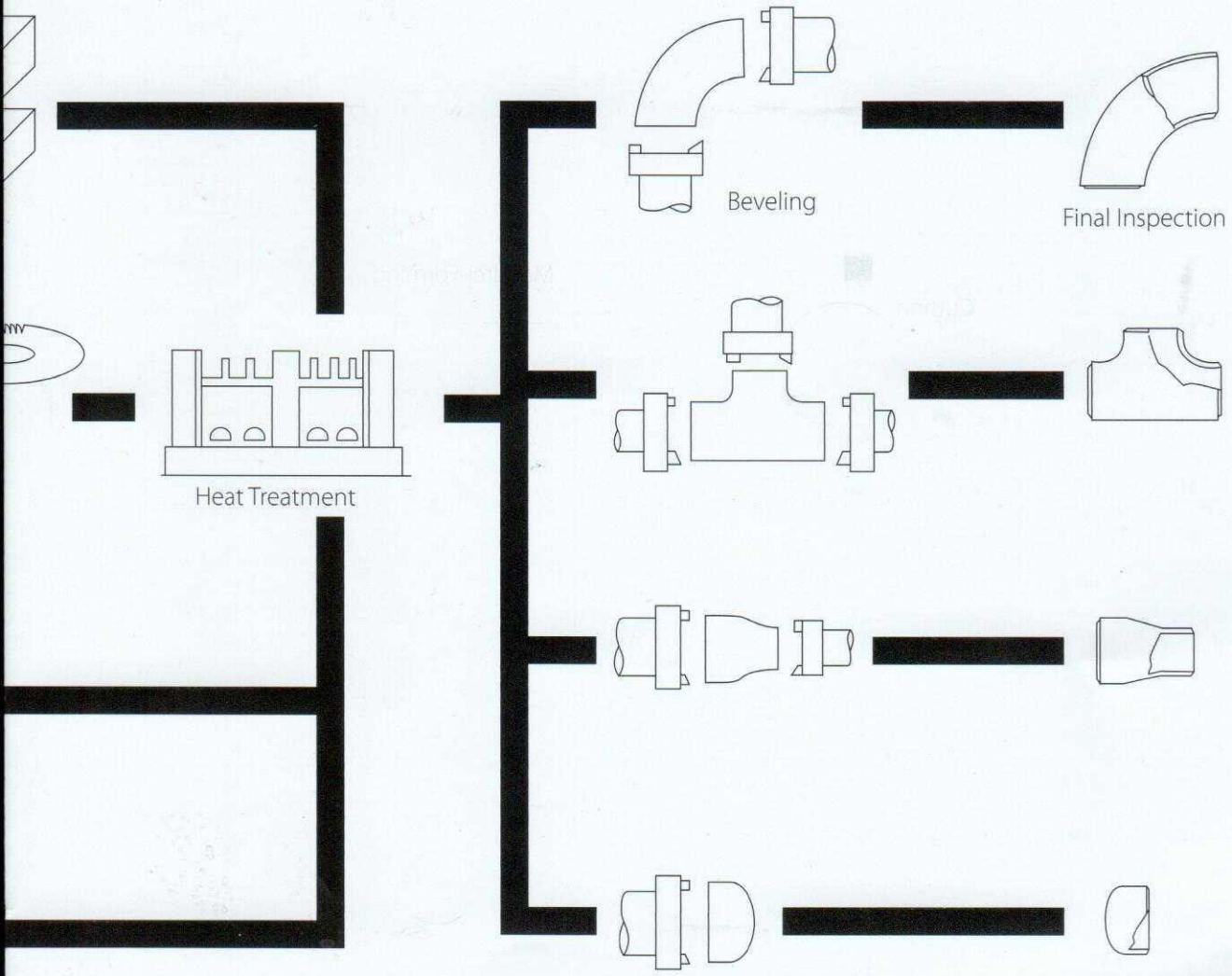

JIS B 2311 / KS B 1522

Outside and Inside Diameters
and Thickness of Pipe Fittings

Steel Butt-Welding Pipe Fittings for Ordinary Use
- Carbon Steel -

FKK

FSGP · PY400

Unit: mm

Nominal diameter		Outside diameter	FSGP		PY400					
			Inside diameter	Thickness	Nominal thickness					
					LG		STD		XS	
A	B	Inside diameter	Thickness	Inside diameter	Thickness	Inside diameter	Thickness	Inside diameter	Thickness	
15	½	21.7	16.1	2.8	-	-	-	-	-	-
20	¾	27.2	21.6	2.8	-	-	-	-	-	-
25	1	34.0	27.6	3.2	-	-	-	-	-	-
32	1¼	42.7	35.7	3.5	-	-	-	-	-	-
40	1½	48.6	41.6	3.5	-	-	-	-	-	-
50	2	60.5	52.9	3.8	-	-	-	-	-	-
65	2½	76.3	67.9	4.2	-	-	-	-	-	-
80	3	89.1	80.7	4.2	-	-	-	-	-	-
100	4	114.3	105.3	4.5	-	-	-	-	-	-
125	5	139.8	130.8	4.5	-	-	-	-	-	-
150	6	165.2	155.2	5.0	-	-	-	-	-	-
200	8	216.3	204.7	5.8	-	-	-	-	-	-
250	10	267.4	254.2	6.6	-	-	-	-	-	-
300	12	318.5	304.7	6.9	-	-	-	-	-	-
350	14	355.6	339.8	7.9	-	-	-	-	-	-
400	16	406.4	390.6	7.9	390.6	7.9	-	-	-	-
450	18	457.2	441.4	7.9	441.4	7.9	-	-	-	-
500	20	508.0	492.2	7.9	492.2	7.9	489.0	9.5	-	-
550	22	558.8	-	-	543.0	7.9	539.8	9.5	533.4	12.7
600	24	609.6	-	-	593.8	7.9	590.6	9.5	584.2	12.7

Remarks:

The nominal thickness for the pipe of PY400 has three kinds of XS, STD and LG corresponding to Extra Strong, Standard and Light Gauge.

Nominal diameter 150A to 300A (6 B to 12 B) for PY400 may be applicable exclusively to the small diameter of reducer and Tee.

Please contact to the manufacturer for any enquiry of the products which have the thickness outside the above description.

Lưu ý:

Độ dày danh nghĩa thể hiện cho ống PY400 có các ký tự viết tắt XS, STD và LG tương ứng lần lượt với Extra Strong, Standard và Light Gauge.

Đường kính danh nghĩa từ size 150A đến 300A (từ 6 B đến 12 B) của ống PY400 có thể được áp dụng riêng cho đường kính nhỏ của Bấu giảm và Tê.

Vui lòng liên hệ với nhà sản xuất đối với những yêu cầu sản phẩm có độ dày khác với độ dày mô tả trong bảng trên.

Shape and Dimensions of Bevel End

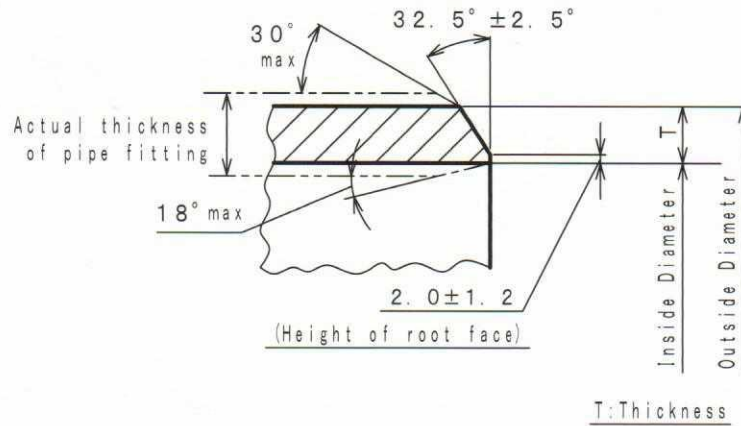

Dimensional Tolerances of Pipe Fittings

Unit: mm

Item	Types of pipe fitting	Nominal diameters					
		A	15~65	80~100	125~200	250~450	500~600
		B	½~2½	3~4	5~8	10~18	20~24
		Tolerances					
Outside diameter at end	All types of pipe fittings	± 2.0	± 2.5	± 3.5	+ 5.0 - 4.5	+ 6.4 - 4.8	
Inside diameter at end		± 2.0	± 2.5	± 3.5	± 4.5	± 4.8	
Thickness		+ not specified - 15%					
Bevel angle		See Figure					
Height of root face		See Figure					
Dimension from center line to end face (H, F)	45° Elbow, 90° Elbow	± 2.0		± 3.2			
Centerline dimension (P)	180° Elbow	± 6.4		± 9.5		-	
Dimension from back to end face (K)		± 6.4					
Alignment of end face (U) (Max.)		1.6		3.2		-	
Overall length (H)	Reducer	± 2.0	± 3.2				
Dimension from centerline to end face (C, M)	Tee	± 2.0	± 3.2				
Dimension from back to end face (E)	Cap	± 3.2	± 6.4				

Tolerances on Squareness with Reference to Centre of Axis of Pipe Fitting

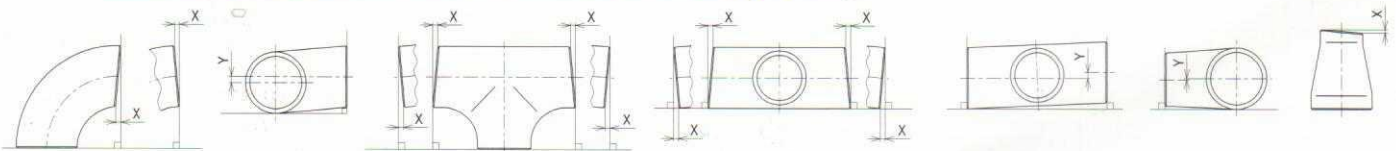

Unit: mm

Item	Types of pipe fittings	Nominal diameters					
		A	15~100	125~200	250~300	350~400	450~600
		B	½~4	5~8	10~12	14~16	18~24
		Tolerances					
Off angle (X)	Elbow, Reducer, Tee	0.8	1.6	2.4		3.2	
Off plane (Y)	Elbow, Tee	1.6	3.2	4.8	6.4	9.5	

JIS B 2312 / KS B 1541

Outside and Inside Diameters
and Thickness of Pipe Fittings

Steel Butt-Welding Pipe Fittings for Ordinary Use
- Carbon, Alloy and Stainless Steel -



CARBON AND ALLOY STEEL

Unit: mm

Nominal diameter		Outside diameter	Nominal thickness			
A	B		Schedule 40		Schedule 80	
			Inside diameter	Thickness	Inside diameter	Thickness
15	½	21.7	16.1	2.8	14.3	3.7
20	¾	27.2	21.4	2.9	19.4	3.9
25	1	34.0	27.2	3.4	25.0	4.5
32	1¼	42.7	35.5	3.6	32.9	4.9
40	1½	48.6	41.2	3.7	38.4	5.1
50	2	60.5	52.7	3.9	49.5	5.5
65	2½	76.3	65.9	5.2	62.3	7.0
80	3	89.1	78.1	5.5	73.9	7.6
100	4	114.3	102.3	6.0	97.1	8.6
125	5	139.8	126.6	6.6	120.8	9.5
150	6	165.2	151.0	7.1	143.2	11.0
200	8	216.3	199.9	8.2	190.9	12.7
250	10	267.4	248.8	9.3	237.2	15.1
300	12	318.5	297.9	10.3	283.7	17.4
350	14	355.6	333.4	11.1	317.6	19.0
400	16	406.4	381.0	12.7	363.6	21.4
450	18	457.2	428.6	14.3	409.6	23.8
500	20	508.0	477.8	15.1	455.6	26.2

STAINLESS STEEL

Unit: mm

Nominal diameter		Outside diameter	Nominal thickness					
A	B		Schedule 5S		Schedule 10S		Schedule 20S	
			Inside diameter	Thickness	Inside diameter	Thickness	Inside diameter	Thickness
15	½	21.7	18.4	1.65	17.5	2.1	16.7	2.5
20	¾	27.2	23.9	1.65	23.0	2.1	22.2	2.5
25	1	34.0	30.7	1.65	28.4	2.8	28.0	3.0
32	1¼	42.7	39.4	1.65	37.1	2.8	36.7	3.0
40	1½	48.6	45.3	1.65	43.0	2.8	42.6	3.0
50	2	60.5	57.2	1.65	54.9	2.8	53.5	3.5
65	2½	76.3	72.1	2.1	70.3	3.0	69.3	3.5
80	3	89.1	84.9	2.1	83.1	3.0	81.1	4.0
100	4	114.3	110.1	2.1	108.3	3.0	106.3	4.0
125	5	139.8	134.2	2.8	133.0	3.4	129.8	5.0
150	6	165.2	159.6	2.8	158.4	3.4	155.2	5.0
200	8	216.3	210.7	2.8	208.3	4.0	203.3	6.5
250	10	267.4	260.6	3.4	259.4	4.0	254.4	6.5
300	12	318.5	310.5	4.0	309.5	4.5	305.5	6.5
350	14	355.6	-	-	-	-	-	-
400	16	406.4	-	-	-	-	-	-
450	18	457.2	-	-	-	-	-	-
500	20	508.0	-	-	-	-	-	-

Remarks: Please contact to the manufacturer for any enquiry of the products which have the thickness outside the above description.

Lưu ý: Vui lòng liên hệ với nhà sản xuất đối với những yêu cầu sản phẩm có độ dày khác với độ dày mô tả trong bảng trên.

Shape and Dimensions of Bevel End

When thickness (T) is 22.4mm or Less

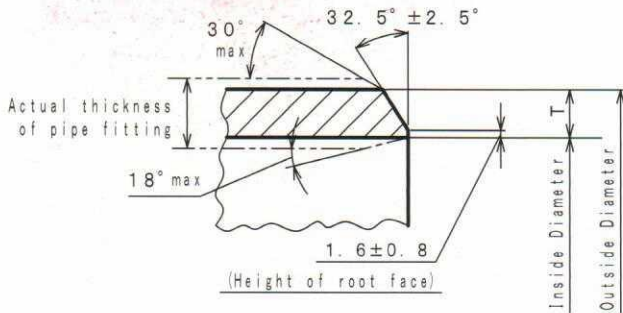

When thickness (T) is 22.4mm

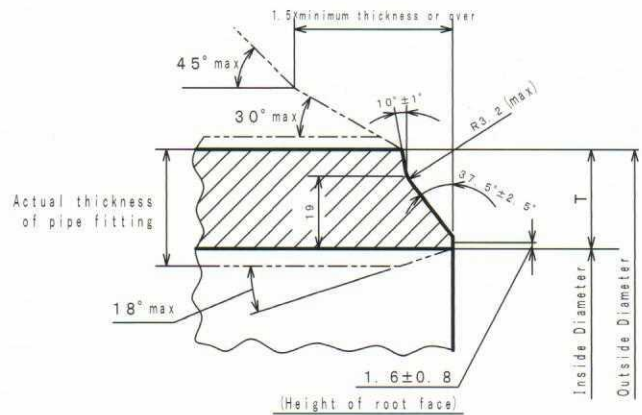

Dimensional Tolerances of Pipe Fittings

Unit: mm

Nominal diameter	Types of pipe fitting	Nominal diameters					
		A	15~65	80~100	125~200	250~450	500
		B	1/2~2 1/2	3~4	5~8	10~18	20
		Tolerances					
Outside diameter at end	All types of pipe fittings		+ 1.6 - 0.8	± 1.6	+ 2.4 - 1.6	+ 4.0 - 3.2	+ 6.4 - 4.8
Inside diameter at end face			± 0.8	± 1.6	± 3.2	± 4.8	
Thickness			+ not specified - 12.5%				
Bevel angle			See Figures				
Height of root face			See Figures				
Dimension from center line to end face (H, F)	45° Elbow, 90° Elbow		± 1.6			± 2.4	
Centerline dimension (P)	180° Elbow		± 6.4			± 9.5	
Dimension from back to end face (K)			± 6.4				
Alignment of end face (U) (Max.)			1.6			3.2	
Overall length (H)	Reducer		± 1.6			± 2.4	
Dimension from centerline to end face (C, M)	Tee		± 1.6			± 2.4	
Dimension from back to end face (E, E ₁)	Cap		± 3.2			± 6.4	

Tolerances on Squareness with Reference to Centre of Axis of Pipe Fitting

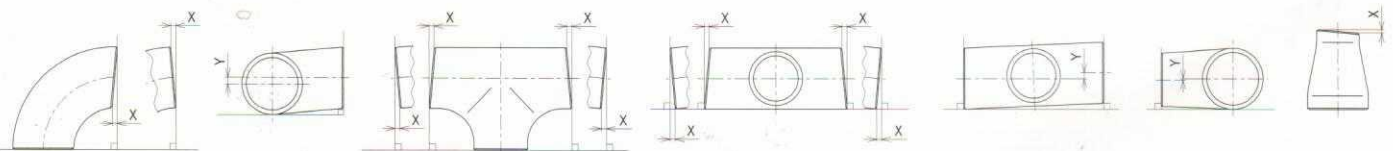

Unit: mm

Item	Types of pipe fittings	Nominal Diameter					
		A	15~100	125~200	250~300	250~400	450~500
		B	1/2~4	5~8	10~12	14~16	18~20
		Tolerances					
Off angle (X)	Elbow, Reducer, Tee		0.8	1.6	2.4	3.2	
Off plane (Y)	Elbow, Tee		1.6	3.2	4.8	6.4	9.5

JIS B 2313 / KS B 1543

Outside and Inside Diameters
and Thickness of Pipe Fittings



Steel Plate Butt-Welding Pipe Fittings
- Carbon, alloy and Stainless Steel -

CARBON, ALLOY STEEL

Unit: mm

Nominal Diameter		Outside Diameter	Carbon, alloy and stainless steel									
			Nominal thickness									
			LG		STD		XS		Schedule 40		Schedule 80	
A	B	Inside Diameter	Thickness	Inside Diameter	Thickness	Inside Diameter	Thickness	Inside diameter	Thickness	Inside diameter	Thickness	
15	½	21.7	-	-	-	-	-	-	16.1	2.8	14.3	3.7
20	¾	27.2	-	-	-	-	-	-	21.4	2.9	19.4	3.9
25	1	34.0	-	-	-	-	-	-	27.2	3.4	25.0	4.5
32	1¼	42.7	-	-	-	-	-	-	35.5	3.6	32.9	4.9
40	1½	48.6	-	-	-	-	-	-	41.2	3.7	38.4	5.1
50	2	60.5	-	-	-	-	-	-	52.7	3.9	49.5	5.5
65	2½	76.3	-	-	-	-	-	-	65.9	5.2	62.3	7.0
80	3	89.1	-	-	-	-	-	-	78.1	5.5	73.9	7.6
100	4	114.3	-	-	-	-	-	-	102.3	6.0	97.1	8.6
125	5	139.8	-	-	-	-	-	-	126.6	6.6	120.8	9.5
150	6	165.2	155.2	5.0	-	-	-	-	151.0	7.1	143.2	11.0
200	8	216.3	204.7	5.8	-	-	-	-	199.9	8.2	190.9	12.7
250	10	267.4	254.2	6.6	-	-	-	-	248.8	9.3	237.2	15.1
300	12	318.5	304.7	6.9	-	-	-	-	297.9	10.3	283.7	17.4
350	14	355.6	339.8	7.9	336.6	9.5	330.2	12.7	333.4	11.1	317.6	19.0
400	16	406.4	390.6	7.9	387.4	9.5	381.0	12.7	381.0	12.7	363.6	21.4
450	18	457.2	441.4	7.9	438.2	9.5	431.8	12.7	428.6	14.3	409.6	23.8
500	20	508.0	492.2	7.9	489.0	9.5	482.6	12.7	477.8	15.1	455.6	26.2

STAINLESS STEEL

Unit: mm

Nominal Diameter		Outside Diameter	Stainless steel					
			Nominal thickness					
			Schedule 5S		Schedule 10S		Schedule 20S	
A	B	Inside diameter	Thickness	Inside diameter	Thickness	Inside diameter	Thickness	
15	½	21.7	18.4	1.65	17.5	2.1	16.7	2.5
20	¾	27.2	23.9	1.65	23.0	2.1	22.2	2.5
25	1	34.0	30.7	1.65	28.4	2.8	28.0	3.0
32	1¼	42.7	39.4	1.65	37.1	2.8	36.7	3.0
40	1½	48.6	45.3	1.65	43.0	2.8	42.6	3.0
50	2	60.5	57.2	1.65	54.9	2.8	53.5	3.5
65	2½	76.3	72.1	2.1	70.3	3.0	69.3	3.5
80	3	89.1	84.9	2.1	83.1	3.0	81.1	4.0
100	4	114.3	110.1	2.1	108.3	3.0	106.3	4.0
125	5	139.8	134.2	2.8	133.0	3.4	129.8	5.0
150	6	165.2	159.6	2.8	158.4	3.4	155.2	5.0
200	8	216.3	210.7	2.8	208.3	4.0	203.3	6.5
250	10	267.4	260.6	3.4	259.4	4.0	254.4	6.5
300	12	318.5	310.5	4.0	309.5	4.5	305.5	6.5
350	14	355.6	347.6	4.0	345.6	5.0	339.6	8.0
400	16	406.4	397.4	4.5	396.4	5.0	390.4	8.0
450	18	457.2	448.2	4.5	447.2	5.0	441.2	8.0
500	20	508.0	498.0	5.0	497.0	5.5	489.0	9.5

Remarks: Please contact to the manufacturer for any enquiry of the products which have the thickness outside the above description.

Lưu ý: Vui lòng liên hệ với nhà sản xuất đối với những yêu cầu sản phẩm có độ dày khác với độ dày mô tả trong bảng trên.



Shape and Dimensions of Bevel End

When thickness (T) is 22.4mm or Less

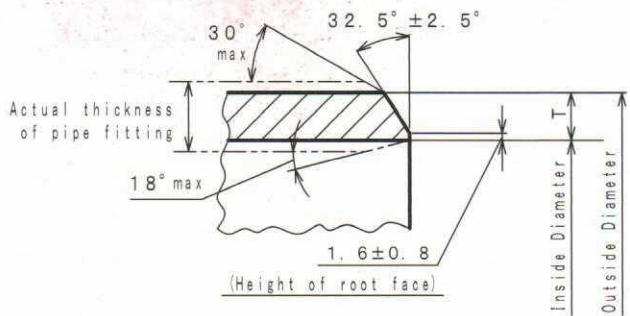

When thickness (T) is 22.4mm

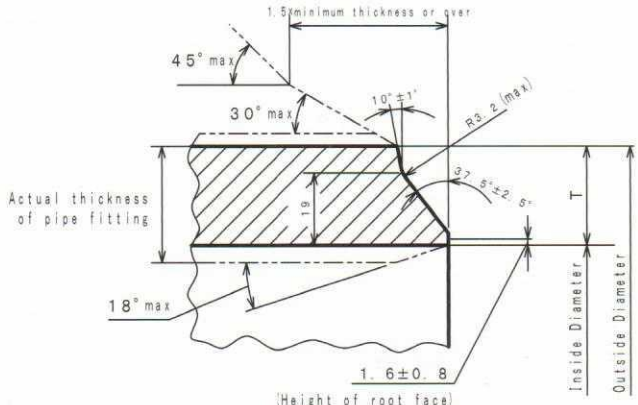

Dimensional Tolerances of Pipe Fittings

Unit: mm

Nominal diameter	Types of pipe fitting	Nominal diameters					
		A	15~65	80~100	125~200	250~450	500~600
		B	1/2~2 1/2	3~4	5~8	10~18	20~24
		Tolerances					
Outside diameter at end	All types of pipe fittings	+ 1.6	±1.6	+ 2.4	+ 4.0	+ 6.4	
		- 0.8		- 1.6	- 3.2	- 4.8	
Inside diameter at end face		± 0.8	± 1.6		± 3.2	± 4.8	
Thickness		+ not specified - 12.5%					
Bevel angle		See Figures					
Height of root face	See Figures						
Dimension from center line to end face (H, F)	45° Elbow, 90° Elbow	± 1.6			± 2.4		
Centerline dimension (P)	180° Elbow	± 6.4			± 9.5	-	
Dimension from back to end face (K)		± 6.4					
Alignment of end face (U) (Max.)		1.6			3.2	-	
Overall length (H)	Reducer	± 1.6			± 2.4		
Dimension from centerline to end face (C, M)	Tee	± 1.6			± 2.4		

Tolerances on Squareness with Reference to Centre of Axis of Pipe Fitting

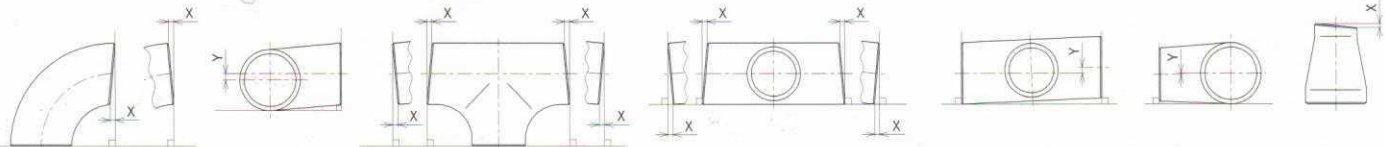

Unit: mm

Item	Types of pipe fittings	Nominal diameters					
		A	15~100	125~200	250~300	250~400	450~500
		B	1/2~4	5~8	10~12	14~16	18~20
		Tolerances					
Off angle (X)	Elbow, Reducer, Tee	0.8	1.6	2.4		3.2	
Off plane (Y)	Elbow, Tee	1.6	3.2	4.8	6.4	9.5	

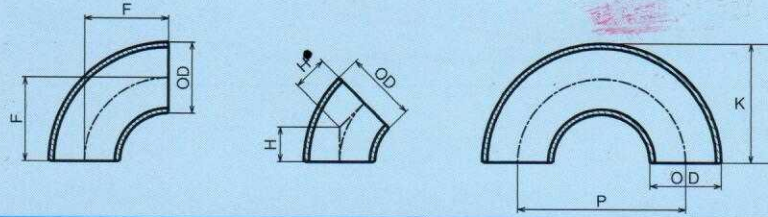
LONG RADIUS ELBOWS
CO DÀI

Unit: mm

Nominal diameter		Outsite diameter OD	Distance from centre to end face		Distance from centre to centre	Distance from centre to end face	Approximate weight kg 90 E (L)		
A	B		F	H	P	K	S G P	S 40	S 80
15	½	21.7	38.1	15.8	76.2	49.0	0.078	0.078	0.098
20	¾	27.2	38.1	15.8	76.2	51.7	0.101	0.104	0.134
25	1	34.0	38.1	15.8	76.2	55.1	0.145	0.153	0.196
32	1¼	42.7	47.6	19.7	95.2	69.0	0.253	0.259	0.341
40	1½	48.6	57.2	23.7	114.4	81.5	0.349	0.368	0.491
50	2	60.5	76.2	31.6	152.4	106.5	0.635	0.651	0.892
65	2½	76.3	95.3	39.5	190.6	133.5	1.12	1.36	1.79
80	3	89.1	114.3	47.3	228.6	158.9	1.58	2.03	2.74
100	4	114.3	152.4	63.1	304.8	209.6	2.91	3.83	5.36
125	5	139.8	190.5	78.9	381.0	260.4	4.49	6.48	9.13
150	6	165.2	228.6	94.7	457.2	311.2	7.09	9.93	15.0
200	8	216.3	304.8	126.3	609.6	413.0	14.4	20.1	30.5
250	10	267.4	381.0	157.8	762.0	514.7	25.4	35.4	56.2
300	12	318.5	457.2	189.4	914.4	616.5	★38.0	★56.2	★92.7
350	14	355.6	533.4	220.9	1066.8	711.2	★56.7	★78.9	★132
400	16	406.4	609.6	252.5	1219.2	812.8	★74.3	★118	★194
450	18	457.2	685.8	284.1	1371.6	914.4	★94.2	★168	★274
500	20	508.0	762.0	315.6	1524.0	1016.0	★116	★219	★372

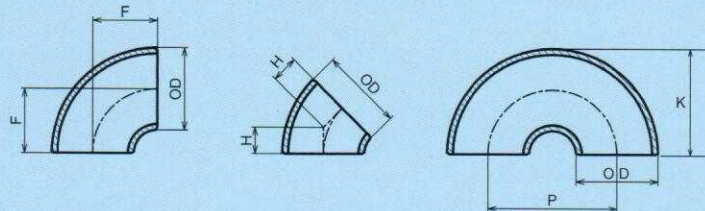
SHORT RADIUS ELBOWS
CO NGẮN

Unit: mm

Nominal diameter		Outsite diameter OD	Distance from centre to end face		Distance from centre to centre	Distance from centre to end face	Approximate weight kg 90 E (S)		
A	B		F	H	P	K	S G P	S 40	S 80
25	1	34.0	25.4	-	50.8	42.4	0.097	0.102	0.130
32	1¼	42.7	31.8	-	63.6	53.2	0.169	0.173	0.228
40	1½	48.6	38.1	15.8	76.2	62.4	0.233	0.245	0.327
50	2	60.5	50.8	21.0	101.6	81.1	0.423	0.434	0.595
65	2½	76.3	63.5	26.3	127.0	101.7	0.744	0.909	1.19
80	3	89.1	76.2	31.6	152.4	120.8	1.05	1.36	1.83
100	4	114.3	101.6	42.1	203.2	158.8	1.94	2.55	3.57
125	5	139.8	127.0	52.6	254.0	196.9	2.99	4.32	6.08
150	6	165.2	152.4	63.1	304.8	235.0	4.72	6.62	10.0
200	8	216.3	203.2	84.2	406.4	311.4	9.60	13.4	20.3
250	10	267.4	254.0	105.2	508.0	387.7	16.9	23.6	37.4
300	12	318.5	304.8	126.2	609.6	464.1	★25.4	★37.4	★61.8
350	14	355.6	355.6	147.3	711.2	533.4	★37.8	★52.6	★88.0
400	16	406.4	406.4	168.3	812.8	609.6	★49.5	★78.6	★130
450	18	457.2	457.2	189.4	914.4	685.8	★62.8	★112	★183
500	20	508.0	508.0	210.4	1016.0	762.0	★77.7	★146	★248

Remark: 1. The weights of 180° are weights of 90° x 2 and weights of 45° are weights of 90° x 1/2. | 2. We do not produce 180° elbows in the parts marked ★
 Lưu ý: 1. Trọng lượng của co 180° bằng trọng lượng của co 90° x 2 và trọng lượng của co 45° bằng trọng lượng của co 90° x 1/2
 2. Chúng tôi không sản xuất co 180° cho những mục đánh dấu ★.

STRAIGHT & REDUCING TEES
TÊ ĐỀU VÀ TÊ GIẢM

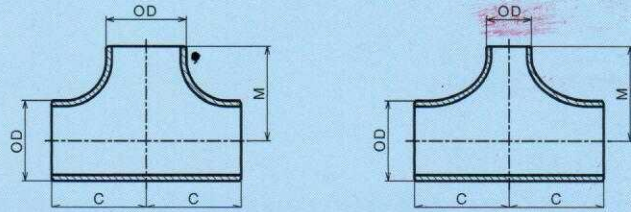

Unit: mm

Nominal diameter		Outsite diameter		Distance from centre to end face		Approximate weight kg		
A	B	OD ₁	OD ₂	C	M	S G P	S 40	S 80
15 x 15	½ x ½	21.7	21.7	25.4	25.4	0.085	0.085	0.107
20 x 20	¾ x ¾	27.2	27.2	28.6	28.6	0.122	0.125	0.162
15	½	27.2	21.7	28.6	28.6	0.116	0.119	0.153
25 x 25	1 x 1	34.0	34.0	38.1	38.1	0.236	0.250	0.318
20	¾	34.0	27.2	38.1	38.1	0.221	0.232	0.297
15	½	34.0	21.7	38.1	38.1	0.213	0.223	0.284
32 x 32	1¼ x 1¼	42.7	42.7	47.6	47.6	0.411	0.421	0.554
25	1	42.7	34.0	47.6	47.6	0.386	0.398	0.521
20	¾	42.7	27.2	47.6	47.6	0.366	0.376	0.493
15	½	42.7	21.7	47.6	47.6	0.356	0.365	0.478
40 x 40	1½ x 1½	48.6	48.6	57.2	57.2	0.573	0.603	0.805
32	1¼	48.6	42.7	57.2	57.2	0.556	0.583	0.776
25	1	48.6	34.0	57.2	57.2	0.525	0.553	0.733
20	¾	48.6	27.2	57.2	57.2	0.500	0.526	0.699
15	½	48.6	21.7	57.2	57.2	0.488	0.511	0.680
50 x 50	2 x 2	60.5	60.5	63.5	63.5	0.851	0.872	1.19
40	1½	60.5	48.6	63.5	60.3	0.791	0.814	1.11
32	1¼	60.5	42.7	63.5	57.2	0.766	0.785	1.07
25	1	60.5	34.0	63.5	50.8	0.724	0.744	1.01
20	¾	60.5	27.2	63.5	44.5	0.698	0.716	0.979
* 15	* ½	60.5	21.7	63.5	44.5	0.693	0.710	0.970
65 x 65	2½ x 2½	76.3	76.3	76.2	76.2	1.42	1.74	2.28
50	2	76.3	60.5	76.2	69.9	1.31	1.56	2.06
40	1½	76.3	48.6	76.2	66.7	1.25	1.51	1.98
32	1¼	76.3	42.7	76.2	63.5	1.22	1.48	1.94
25	1	76.3	34.0	76.2	57.2	1.18	1.44	1.88
80 x 80	3 x 3	89.1	89.1	85.7	85.7	1.87	2.41	3.25
65	2½	89.1	76.3	85.7	82.6	1.79	2.29	3.07
50	2	89.1	60.5	85.7	76.2	1.67	2.11	2.85
40	1½	89.1	48.6	85.7	73.0	1.62	2.06	2.77
32	1¼	89.1	42.7	85.7	69.9	1.59	2.03	2.73
* 25	* 1	89.1	34.0	85.7	69.9	1.57	2.01	2.70
100 x 100	4 x 4	114.3	114.3	104.8	104.8	3.13	4.12	5.76
80	3	114.3	89.1	104.8	98.4	2.92	3.82	5.33
65	2½	114.3	76.3	104.8	95.3	2.84	3.70	5.15
50	2	114.3	60.5	104.8	88.9	2.72	3.53	4.93
40	1½	114.3	48.6	104.8	85.7	2.66	3.47	4.85
* 32	* 1¼	114.3	42.7	104.8	85.7	2.65	3.46	4.83
* 25	* 1	114.3	34.0	104.8	85.7	2.62	3.43	4.79
125 x 125	5 x 5	139.8	139.8	123.8	123.8	4.52	6.53	9.20
100	4	139.8	114.3	123.8	117.5	4.30	6.13	8.62
80	3	139.8	89.1	123.8	111.1	4.08	5.83	8.18
65	2½	139.8	76.3	123.8	108.0	4.00	5.71	8.01
50	2	139.8	60.5	123.8	104.8	3.90	5.56	7.81
* 40	* 1½	139.8	48.6	123.8	104.8	3.85	5.51	7.75

Remark: Nominal diameters marked * are not specified in JIS
 Lưu ý: Những mục có đường kính danh nghĩa đánh dấu * không có trong tiêu chuẩn JIS.

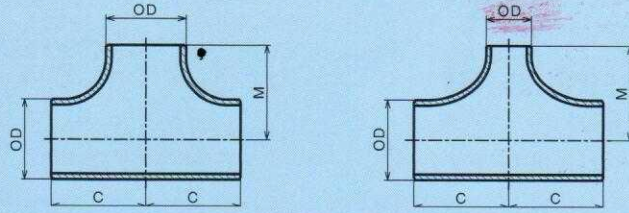
STRAIGHT & REDUCING TEES
TÊ ĐỀU VÀ TÊ GIẢM

Unit: mm

Nominal diameter		Outsite diameter		Distance from centre to end face		Approximate weight kg		
A	B	OD ₁	OD ₂	C	M	S G P	S 40	S 80
150 x 150	6 x 6	165.2	165.2	142.9	142.9	6.83	9.58	14.5
125	5	165.2	139.8	142.9	136.5	6.45	9.08	13.6
100	4	165.2	114.3	142.9	130.2	6.22	8.67	13.0
80	3	165.2	89.1	142.9	123.8	6.00	8.37	12.6
65	2½	165.2	76.3	142.9	120.7	5.93	8.25	12.4
* 50 *	2	165.2	60.5	142.9	120.7	5.85	8.12	12.2
200 x 200	8 x 8	216.3	216.3	177.8	177.8	12.8	17.9	27.1
150	6	216.3	165.2	177.8	168.3	11.9	16.6	25.2
125	5	216.3	139.8	177.8	161.9	11.5	16.1	24.3
100	4	216.3	114.3	177.8	155.6	11.3	15.7	23.7
* 80 *	3	216.3	89.1	177.8	152.4	11.1	15.5	23.3
250 x 250	10 x 10	267.4	267.4	215.9	215.9	21.9	30.4	48.3
200	8	267.4	216.3	215.9	203.2	20.4	28.5	45.0
150	6	267.4	165.2	215.9	193.7	19.5	27.2	43.1
125	5	267.4	139.8	215.9	190.5	19.2	26.8	42.3
100	4	267.4	114.3	215.9	184.2	18.9	26.4	41.7
300 x 300	12 x 12	318.5	318.5	254.0	254.0	31.9	47.2	77.8
250	10	318.5	267.4	254.0	241.3	30.4	44.6	73.3
200	8	318.5	216.3	254.0	228.6	29.0	42.7	70.0
150	6	318.5	165.2	254.0	219.1	28.1	41.4	68.1
125	5	318.5	139.8	254.0	215.9	27.8	41.0	67.3
350 x 350	14 x 14	355.6	355.6	279.4	279.4	44.7	62.2	104
300	12	355.6	318.5	279.4	269.9	42.7	59.9	100
250	10	355.6	267.4	279.4	257.2	41.2	57.4	95.5
200	8	355.6	216.3	279.4	247.7	39.9	55.6	92.5
150	6	355.6	165.2	279.4	238.1	39.0	54.3	90.6
400 x 400	16 x 16	406.4	406.4	304.8	304.8	55.2	84.7	-
350	14	406.4	355.6	304.8	304.8	54.2	84.7	-
300	12	406.4	318.5	304.8	295.3	52.2	82.3	-
250	10	406.4	267.4	304.8	282.6	50.7	79.8	-
200	8	406.4	216.3	304.8	273.1	49.4	78.1	-
150	6	406.4	165.2	304.8	263.5	48.5	76.8	-
450 x 450	18 x 18	457.2	457.2	342.9	342.9	70.0	125	-
400	16	457.2	406.4	342.9	330.2	67.9	120	-
350	14	457.2	355.6	342.9	330.2	66.9	117	-
300	12	457.2	318.5	342.9	320.7	64.9	114	-
250	10	457.2	267.4	342.9	308.0	63.9	112	-
200	8	457.2	216.3	342.9	298.5	62.1	110	-
500 x 500	20 x 20	508.0	508.0	381.0	381.0	86.6	163	-
450	18	508.0	457.2	381.0	368.3	84.2	158	-
400	16	508.0	406.4	381.0	355.6	82.1	152	-
350	14	508.0	355.6	381.0	355.6	81.1	149	-
300	12	508.0	318.5	381.0	346.1	80.1	147	-
250	10	508.0	267.4	381.0	333.4	79.0	145	-
200	8	508.0	216.3	381.0	323.9	76.9	143	-

**CONCENTRIC
& ECCENTRIC REDUCERS**
BẦU GIẢM ĐỒNG TÂM
VÀ BẦU GIẢM LỆCH TÂM

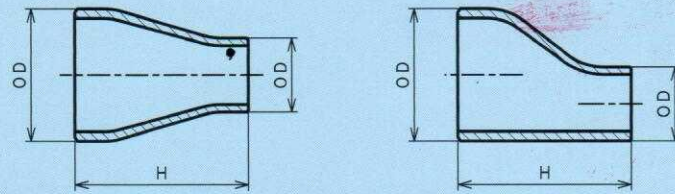

Unit: mm

Nominal diameter		Outsite diameter		Distance from centre to end face	Approximate weight kg		
A	B	OD ₁	OD ₂	H	S G P	S 40	S 80
20 x 15	¾ x ½	27.2	21.7	38.1	0.057	0.059	0.075
25 x 20	1 x ¾	34.0	27.2	50.8	0.110	0.116	0.147
15	½	34.0	21.7	50.8	0.100	0.105	0.133
32 x 25	1¼ x 1	42.7	34.0	50.8	0.153	0.157	0.206
20	¾	42.7	27.2	50.8	0.139	0.143	0.186
15	½	42.7	21.7	50.8	0.128	0.132	0.171
40 x 32	1½ x 1¼	48.6	42.7	63.5	0.231	0.244	0.324
25	1	48.6	34.0	63.5	0.208	0.220	0.291
20	¾	48.6	27.2	63.5	0.191	0.201	0.266
15	½	48.6	21.7	63.5	★0.177	★0.187	★0.245
50 x 40	2 x 1½	60.5	48.6	76.2	0.363	0.372	0.508
32	1¼	60.5	42.7	76.2	0.343	0.352	0.479
25	1	60.5	34.0	76.2	0.315	0.322	0.438
20	¾	60.5	27.2	76.2	★0.293	★0.300	★0.406
65 x 50	2½ x 2	76.3	60.5	88.9	0.593	0.723	0.945
40	1½	76.3	48.6	88.9	0.542	0.660	0.861
32	1¼	76.3	42.7	88.9	0.518	0.630	0.820
25	1	76.3	34.0	88.9	★0.482	★0.585	★0.759
80 x 65	3 x 2½	89.1	76.3	88.9	0.724	0.933	1.25
50	2	89.1	60.5	88.9	0.658	0.846	1.13
40	1½	89.1	48.6	88.9	0.610	0.783	1.05
32	1¼	89.1	42.7	88.9	★0.587	★0.752	★1.00
* 25	* 1	89.1	34.0	88.9	★0.553	★0.707	★0.941
100 x 80	4 x 3	114.3	89.1	101.6	1.10	1.45	2.02
65	2½	114.3	76.3	101.6	1.04	1.36	1.90
50	2	114.3	60.5	101.6	0.966	1.27	1.76
40	1½	114.3	48.6	101.6	★0.911	★1.19	★1.65
125 x 100	5 x 4	139.8	114.3	127.0	1.73	2.50	3.51
80	3	139.8	89.1	127.0	1.58	2.27	3.18
65	2½	139.8	76.3	127.0	1.50	2.16	3.02
50	2	139.8	60.5	127.0	★1.41	★2.02	★2.82
150 x 125	6 x 5	165.2	139.8	139.7	2.55	3.57	5.38
100	4	165.2	114.3	139.7	2.36	3.30	4.96
80	3	165.2	89.1	139.7	2.18	3.04	4.56
65	2½	165.2	76.3	139.7	★2.09	★2.92	★4.36
* 50	* 2	165.2	60.5	139.7	★1.98	★2.76	★4.12

Remark: 1. Nominal diameters marked * are not specified in JIS
2. We do not produce eccentric reducer in the parts marked *

Lưu ý: 1. Những mục có đường kính danh nghĩa đánh dấu * không có trong tiêu chuẩn JIS.
2. Chúng tôi không sản xuất bầu giảm lệch tâm cho những mục đánh dấu *

CÔNG TY TNHH THÉP BẢO TÍN
MST: 0311458762
100 Trần Thị Cờ, P.Thới An, Q.12, TP.HCM
Tel: 08.6259 3033 - Fax: 08.6259 3038

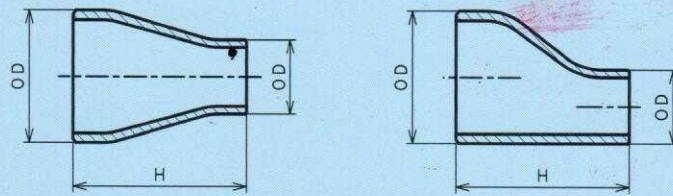
**CONCENTRIC
& ECCENTRIC REDUCERS**
 BẦU GIẢM ĐỒNG TÂM
 VÀ BẦU GIẢM LỆCH TÂM

Unit: mm

Nominal diameter		Outsite diameter		Distance from centre to end face	Approximate weight kg		
A	B	OD ₁	OD ₂	H	S G P	S 40	S 80
200 x 150	8 x 6	216.3	165.2	152.4	4.08	5.70	8.61
125	5	216.3	139.8	152.4	3.87	5.39	8.13
100	4	216.3	114.3	152.4	3.66	5.10	7.68
250 x 200	10 x 8	267.4	216.3	177.8	6.87	9.58	15.2
150	6	267.4	165.2	177.8	6.31	8.78	13.9
125	5	267.4	139.8	177.8	6.05	8.41	13.3
300 x 250	12 x 10	318.5	267.4	203.2	9.96	14.7	24.2
200	8	318.5	216.3	203.2	9.28	13.7	22.5
150	6	318.5	165.2	203.2	8.68	12.8	20.9
350 x 300	14 x 12	355.6	318.5	330.2	21.2	29.5	49.3
250	10	355.6	267.4	330.2	19.7	27.4	45.6
200	8	355.6	216.3	330.2	18.3	25.4	42.2
450 x 350	16 x 14	406.4	355.6	355.6	25.9	41.1	67.6
300	12	406.4	318.5	355.6	24.7	39.2	64.5
250	10	406.4	267.4	355.6	23.2	36.8	60.3
200	8	406.4	216.3	355.6	★21.7	★34.4	★56.3
450 x 400	18 x 16	457.2	406.4	381.0	31.5	56.2	91.4
350	14	457.2	355.6	381.0	29.8	53.1	86.3
300	12	457.2	318.5	381.0	★28.6	★51.0	★82.7
250	10	457.2	267.4	381.0	★27.1	★48.2	★78.0
500 x 450	20 x 18	508.0	457.2	508.0	★47.0	★88.5	★150
400	16	508.0	406.4	508.0	★44.7	★84.0	★142
350	14	508.0	355.6	508.0	★42.4	★79.7	★135
300	12	508.0	318.5	508.0	★40.8	★76.6	★129



CAPS
BỊT CHỤP

CÔNG TY TNHH THÉP BẢO TÍN
MST : 0311458762
 100 Trần Thị Cờ, P.Thới An, Q.12, TP.HCM
 Tel : 08.6259 3033 - Fax : 08.6259 3038

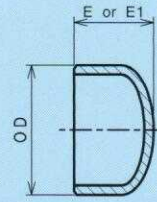

Unit: mm

Nominal diameter		Outside diameter	Distance from centre to end face			Approximate weight kg		
A	B	OD	E	E ₁	Wall thickness limit	S G P	S 40	S 80
15	½	21.7	25.4	-	-	0.038	0.038	0.051
20	¾	27.2	25.4	-	-	0.048	0.049	0.067
25	1	34.0	38.1	-	-	0.103	0.109	0.144
32	1¼	42.7	38.1	-	-	0.141	0.145	0.197
40	1½	48.6	38.1	-	-	0.162	0.171	0.236
50	2	60.5	38.1	44.5	5.5	0.228	0.234	0.330
65	2½	76.3	38.1	50.8	7.0	0.339	0.420	0.565
80	3	89.1	50.8	63.5	7.6	0.507	0.664	0.917
100	4	114.3	63.5	76.2	8.6	0.877	1.17	1.68
125	5	139.8	76.2	88.9	9.5	1.29	1.90	2.73
150	6	165.2	88.9	101.6	11.0	1.99	2.83	4.38
200	8	216.3	101.6	127.0	12.7	3.61	5.11	7.91
250	10	267.4	127.0	152.4	12.7	6.33	8.92	16.4
300	12	318.5	152.4	177.8	12.7	9.43	14.1	26.4
350	14	355.6	165.1	190.5	12.7	13.2	18.6	34.9
400	16	406.4	177.8	203.2	12.7	16.6	26.7	49.0
450	18	457.2	203.2	228.6	12.7	21.2	41.5	69.0
500	20	508.0	228.6	254.0	12.7	26.4	54.1	93.8

Remark: 1. The distance from back arch to end face of Cap shall be E when the thickness is up to the thickness limit and E₁ when the thickness exceeds the wall thickness limit.
 2. The shape of the cap shall be semi ellipsoidal, and the ratio of the long diameter to the short one at inside surface shall be more than 1, but not more than 2.

Lưu ý: 1. E là khoảng cách từ mặt cong phía sau đến điểm đầu của mặt trên chén khi độ dày nằm trong giới hạn bề dày và E₁ khi độ dày vượt quá giới hạn bề dày.
 2. Hình dạng của chén (bịt chụp) là hình bán elip. Tỷ lệ của đường kính dài và đường kính ngắn ở mặt trong sẽ lớn hơn 1 và không được lớn hơn 2.





MAIN CUSTOMERS IN JAPAN

REFINING & PETROCHEMICALS, GENERAL CHEMICAL

- » ASAHI KASEI CORPORATION
- » COSMO OIL CO., LTD.
- » JX NIPPON OIL & ENERGY CORPORATION
- » SEKISUI CHEMICAL CO., LTD.
- » DENKI KAGAKU KOGYO KABUSHIKI GAISYA
- » TOAGOSEI CO., LTD.
- » TONEN GENERAL SEKIYU K.K
- » MITSUI CHEMICALS, INC.
- » MITSUBISHI CHEMICAL CORPORATION

PLANT CONSTRUCTION

- » COSMO ENGINEERING CO., LTD.
- » JFE ENGINEERING CORPORATION
- » SHINKO PLANTECH CO., LTD.
- » SHINKO ENGINEERING & MAINTENANCE CO., LTD.
- » CHIYODA CORPORATION
- » TOYO ENGINEERING CORPORATION
- » TORAY ENGINEERING CO., LTD.
- » NISHINIPPON PLANT ENGINEERING AND CONSTRUCTION CO., LTD.
- » JGC CORPORATION
- » HITACHI, LTD.
- » MITSUBISHI KAKOKI KAISHA, LTD.

GAS

- » OSAKA GAS CO., LTD.
- » OTAKI GAS CO., LTD.
- » KEIYO GAS CORPORATION
- » NIPPON STEEL & SUMITOMO PIPELINE & ENGINEERING CO., LTD.
- » SAIBU GAS CO., LTD.
- » CHIBA GAS CO., LTD.
- » OKINAWA GAS CO., LTD.
- » BUSHU GAS CO., LTD.
- » CHUBU GAS CO., LTD.
- » TOKYO GAS CO., LTD.
- » TOHO GAS CO., LTD.
- » HIROSHIMA GAS CO., LTD.
- » BUYO GAS CO., LTD.
- » HOKKAIDO GAS CO., LTD.
- » HOKURIKU GAS CO., LTD.

SHIPBUILDING

- » IHI CORPORATION
- » KAWASAKI HEAVY INDUSTRIES, LTD.
- » SANOYAS HOLDING CORPORATION
- » KOYO DOCKYARD COMPANY, LIMITED
- » MITSUI ENGINEERING & SHIPBUILDING CO., LTD.
- » MITSUBISHI HEAVY INDUSTRIES, LTD.
- » JAPAN MARINE UNITED CORPORATION

STEEL

- » KOBE STEEL, LTD.
- » JFE STEEL CORPORATION
- » NIPPON STEEL & SUMITOMO METAL CORPORATION

ELECTRIC POWER

- » THE KANSAI ELECTRIC POWER CO., INC.
- » KYUSYU ELECTRIC POWER CO., INC.
- » SHARP CORPORATION
- » TAIHEI DENGYO KAISYA, LTD.
- » THE CHUGOKU ELECTRIC POWER CO., INC.
- » CHUBU ELECTRIC POWER CO., INC.
- » TOKYO ELECTRIC POWER COMPANY, INC.
- » TOSHIBA CORPORATION
- » TOHOKU ELECTRIC POWER CO., INC.
- » HOKURIKU ELECTRIC POWER COMPANY
- » MITSUBISHI ELECTRIC CORPORATION

OTHER

- » IMEX CO., LTD.
- » ASAHI KOGYOSHA CO., LTD.
- » ASAHI SYNCHROTECH CO., LTD.
- » ISHII IRON WORKS CO., LTD.
- » EBARA CORPORATION
- » ORGANO CORPORATION
- » KAWASAKI THERMAL ENGINEERING CO., LTD.
- » KUBOTA CORPORATION
- » KURITA WATER INDUSTRIES LTD.
- » KURE ENGINEERING LTD.
- » KODA KOJI K.K.
- » KOBELCO CONSTRUCTION MACHINERY CO., LTD.
- » SAIKYU KOGYO CO., LTD.
- » SASAKURA ENGINEERING CO., LTD.
- » SANKI ENGINEERING CO., LTD.
- » SANKEN SETSUBI KOGYO CO., LTD.
- » SHIN NIPPON AIR TECHNOLOGIES CO., LTD.
- » SHINRYO CORPORATION.
- » SUGA CO., LTD.
- » DAIICHI SETSUBI ENGINEERING CORPORATION.
- » TAIKISHA LTD.
- » TAISEI ONCHO CO., LTD.
- » TAISEI SETSUBI CO., LTD.
- » DAISEL CORPORATION
- » DAI-DAN CO., LTD.
- » TAKASAGO THERMAL ENGINEERING CO., LTD.
- » TAK MANUFACTURING CO., LTD.
- » TAKUMA CO., LTD.
- » CHISSO CORPORATION.
- » TECHNO RYOWA LTD.
- » TONETS CORPORATION
- » NISSHIN REFRIGERATION & ENGINEERING LTD.
- » NIPPON CHEMICAL INDUSTRIAL CO., LTD.
- » HIBIYA ENGINEERING LTD.
- » FUJICAR MFG. LTD.
- » SUMITOMO (S.H.I.) CONSTRUCTION MACHINERY CO., LTD.
- » TADANO LTD.
- » KOMATSU MACHINE CONSTRUCTION
- » HITACHI CONSTRUCTION MACHINERY CO., LTD.
- » KINDEN CORPORATION
- » KANDEN ENGINEERING CO.

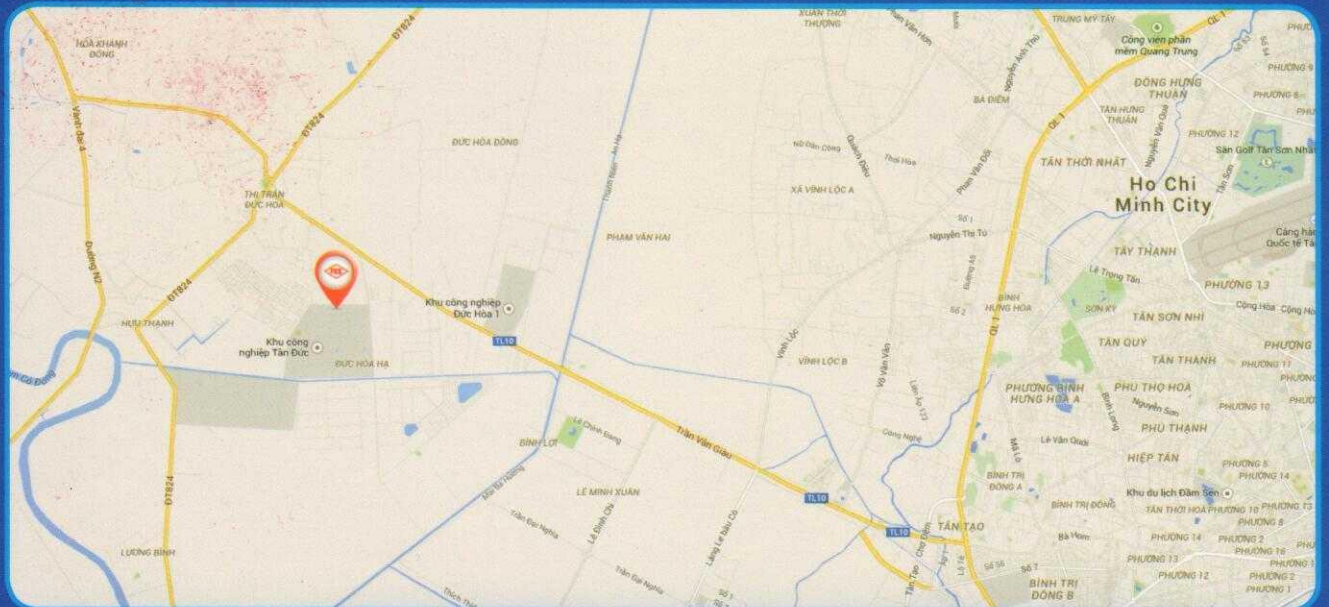

JIS B 2311, 2312, 2313
KS B 1522, 1541, 1543
ISO 9001

FURUBAYASHI KOGYO KABUSHIKIGAI SYA VIETNAM
FKK VIETNAM

Head Office and Factory:

Lot 21, Road 1, Tan Duc Industrial Zone,
Duc Hoa District, Long An Province, VN
Tel: (+84) 72-3769-662
Fax: (+84) 72-3769-664

HCMC Office:

Room 101, Morning Sun Building,
404 Hoang Dieu Street, Ward 5, District 4, HCMC, VN
Tel: (+84) 8-3943-4816
Fax: (+84) 8-3943-4815

Japan Office:

3-17, 3-Chome, Tsumori, Nishirari-ku, Osaka-Japan.
Tel: (+81) 6-6659-1234
Fax: (+81) 6-6658-8500